

UNIMOTION

PRODUCT OVERVIEW

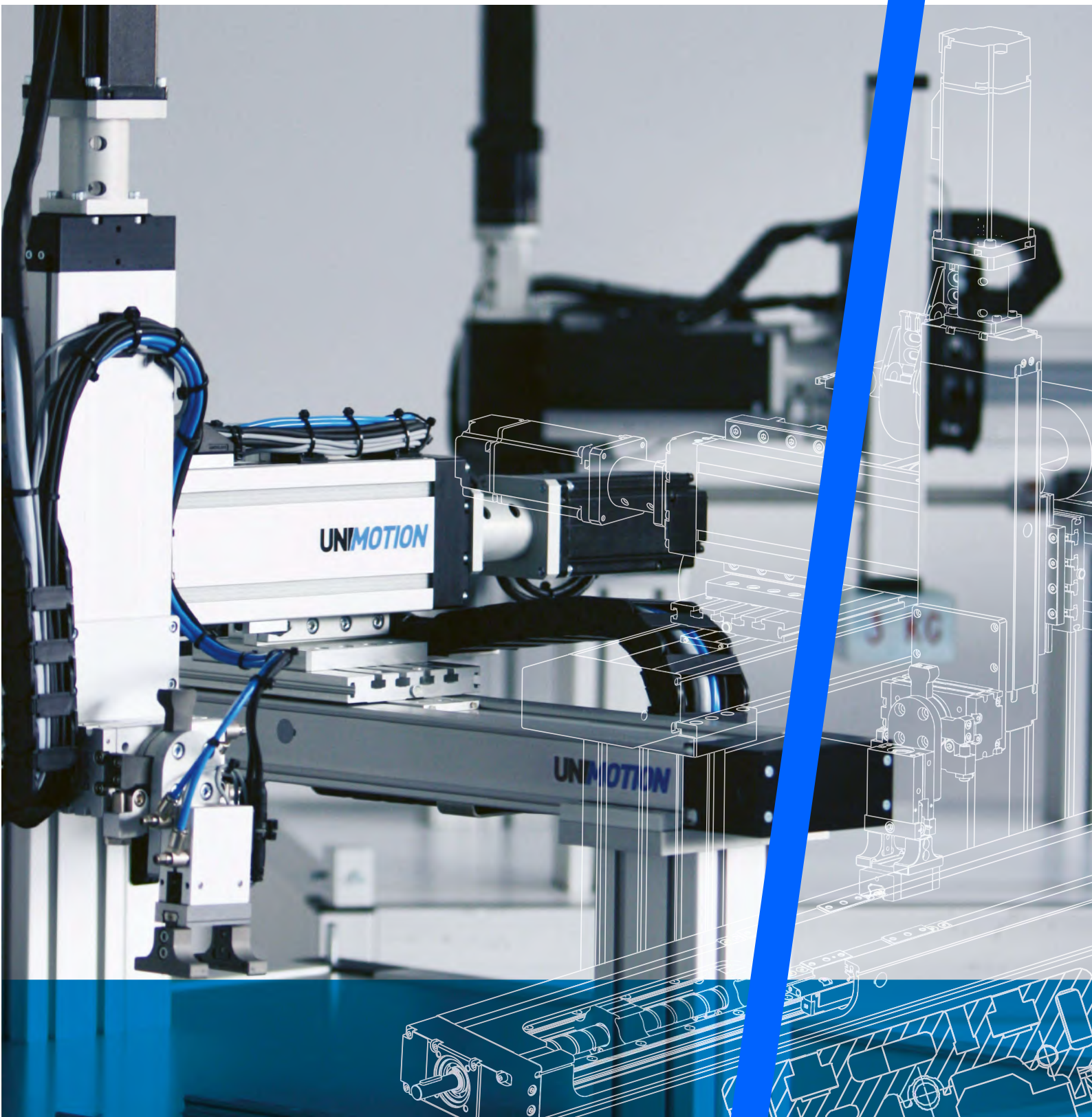

About Us

Our company was established in 1990 and, since then, it is privately owned. After 7 years of experience in metal processing as a contractor, the company Hypex (Unimotion) was created and operated in the following areas: special purpose machinery manufacture with its own development, trade and assembly in the area of industrial automation.

Due to many years of engineering and substantial engagement in individual problem solving processes, extensive knowledge and experience in the development and manufacture of linear and handling systems were gained. Today we produce mechanical linear units, compact linear units, multi-axis systems as well as customised solutions for high dynamic demands.

Our company's premises, which cover an area of 4500m², offer room for our 75 employees. Production, construction, administration and warehouse; all this can be found under one roof.

Our modern machinery with CNC machining centres and CNC automatic lathes enables high-precision manufacture and really high in-house production depth. For example, we ourselves manufacture shaft drives with tooth washers and our screw ends. This is why, quality, reliability, a good price/performance ratio and short delivery times are harmonised to perfection.

Thus, in the production of our standard linear units as well as individual and complex special linear units, we can guarantee high capacity, flexibility and precision.

At the moment, we export our products in more than 30 countries. Inspired by our customers' demands, Hypex (Unimotion) constantly develops new products and system solutions. So you are welcome to contact us. We look forward to meet you and work on your special project!

Unimotion products
have the quality and
standards to meet
the requirements
of the modern market.

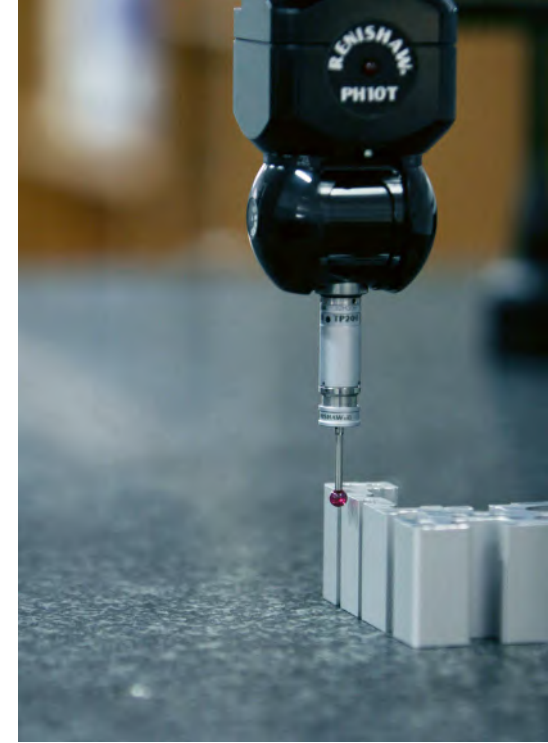

ALL UNDER ONE ROOF

PRODUCTION, CONSTRUCTION, ENGINEERING AND WAREHOUSE

We operate in the field of customized machinery, offering individual and integrated solutions such as testing machines and assembly lines with its own development. Experience in long-term individual technology solutions has led the company to become a linear motion technology solution provider.

25 YEARS OF EXPERIENCE



Our modern machinery with various CNC machining centres and CNC automatic lathes enables high-precision manufacturing and in-depth in-house production capabilities. For example, we ourselves manufacture the drive shafts with the pulleys and machine the ball screw ends.

We ensure the constant quality and performances for our outstanding products through the following machines:

- annealing machine station for the ball screw
- straightening machine
- several CNC machines and automatic lathes with power tools
- two 4-axis machining centres with a highly modern, fully automated pallet changing system
- high precision CNC machining machine with a travel distance of 3.5m,
- 5-axis CNC machine with a travel distance of 7m for 5-axis sawing, drilling and machining jobs where our linear-axis profiles are machined
- one Wenzel 6m-long CNC measuring machine
- one Wenzel 3D coordinate CNC measuring machine

This is why, quality, reliability, a good price/performance ratio and short delivery times are harmonised to perfection. Thus, in the production of our standard linear units as well as individual and complex special linear units, we can guarantee high capacity, flexibility and precision.

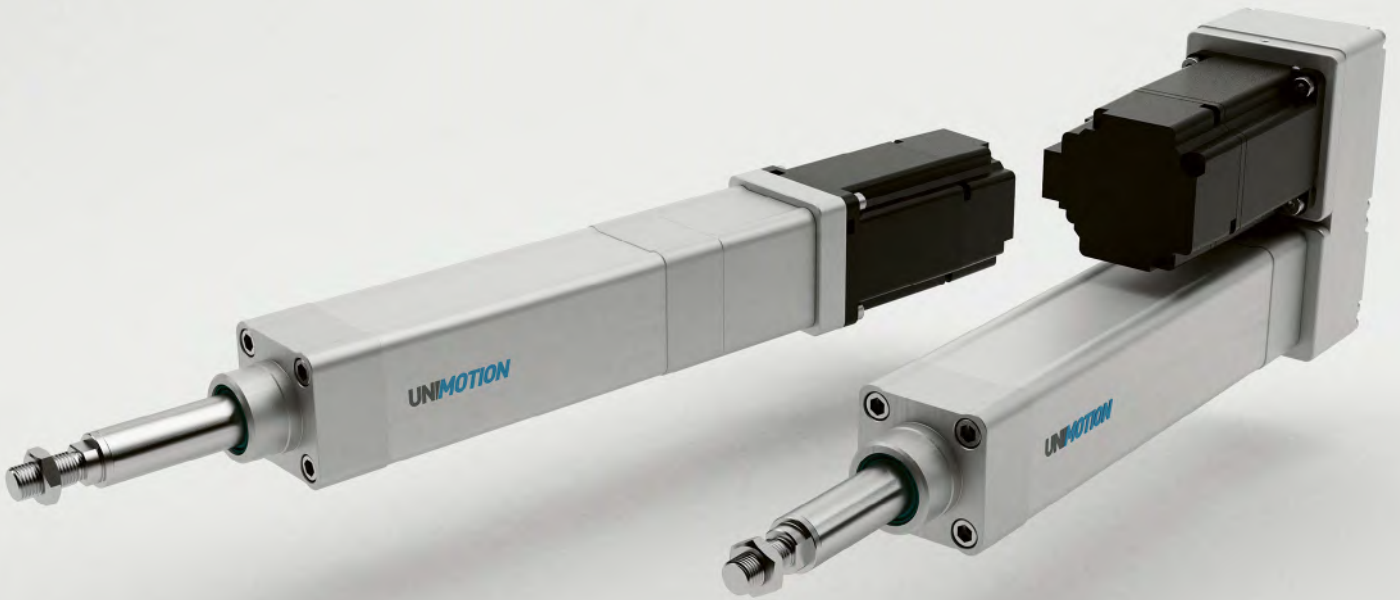

ELECTRIC CYLINDERS

PNCE SERIES - 32, 40, 50, 63, 80, 100



The PNCE are electric cylinders with a precision ball screw drive. The electric cylinder is based on the standard ISO 15552. Its outer design and dimensions are very similar to pneumatic cylinders.

High performance features such as:
 - high speeds,
 - good positioning accuracy and
 - high repeatability

are ensured through a precision ball screw with reduced backlash (preload on request) of the ball nut and non-rotating piston rod. For a long service life the re-lubrication can be done through a lubrication nipple.

The design with its smooth surfaces enables easy cleaning of the cylinder. In combination with a lubricant class H1 it is also suitable for food & beverage applications. It can be additionally equipped with switches and ISO standard accessories.

Maximum stroke: 1500 mm
Maximum travel speed: 2,5 m/s

Maximum axial load: 29000 N
Axial backlash: < 0,02 mm

STANDARD VERSION

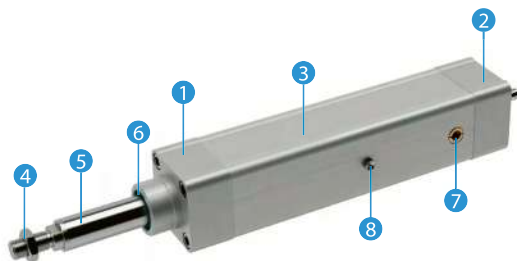

- 1 - Front cap
- 2 - Drive cap
- 3 - Smooth cylinder profile
- 4 - Hex nut
- 5 - Piston rod (stainless steel) with an anti-rotation device
- 6 - Piston rod seal
- 7 - Pressure compensation
- 8 - Lubrication nipple

OPTIONS

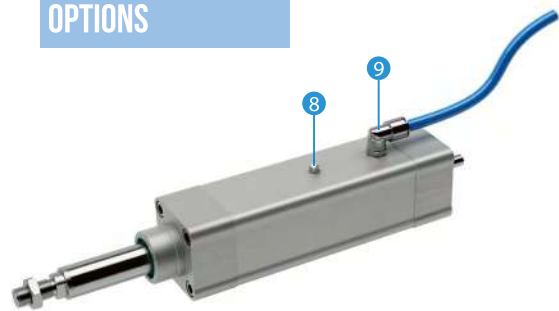

- 8 - Lubrication nipple
- 9 - Connection for pressure compensation

• IP65 protection class (IP65)

• IP65 protection class with corrosion resistance (IP65CR)

• For applications in the food industry (FI)



BELT DRIVE

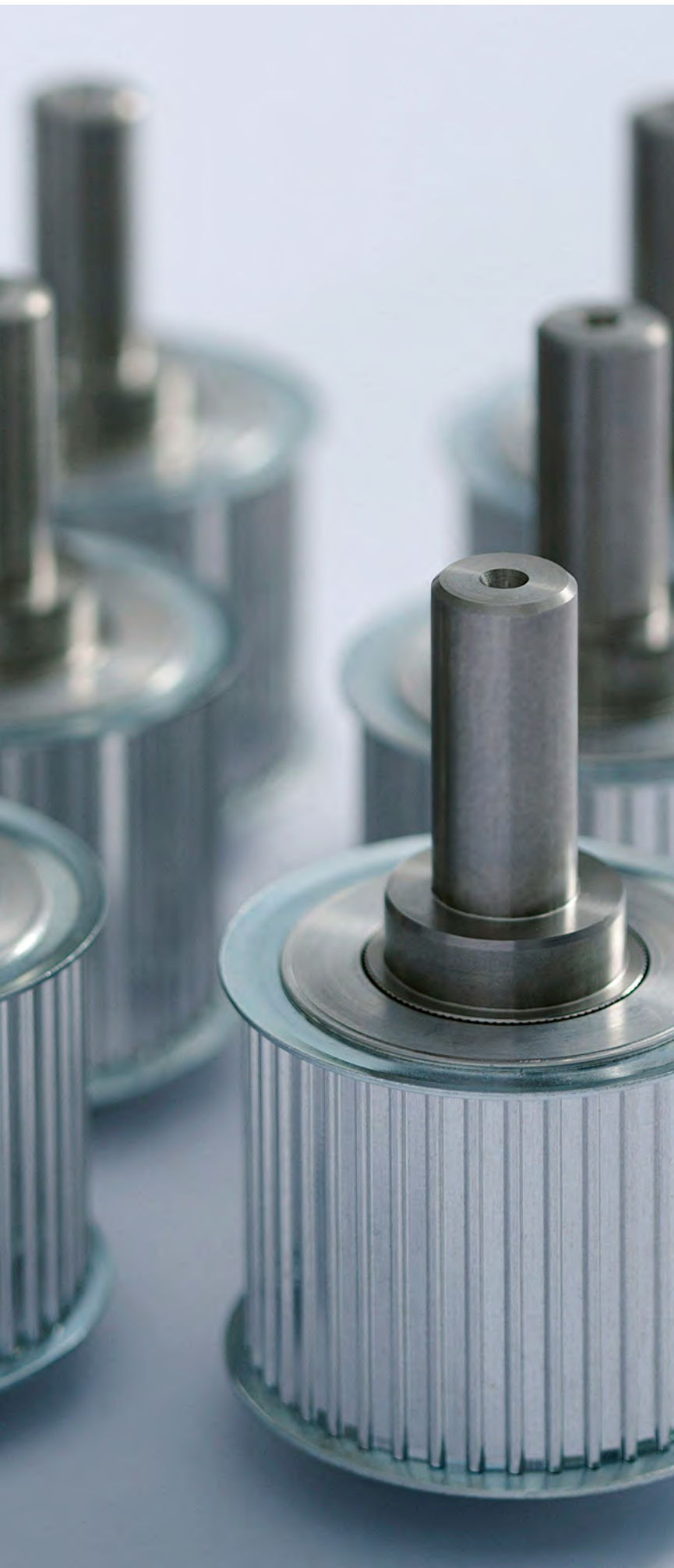

CTJ SERIES - 90, 110, 145, 200



MTJ AND MRJ SERIES - 40, 65, 80, 110



MTJ Z SERIES - 40, 65, 80, 110



MTJ ECO SERIES - 40





A compact linear unit with an AT toothed belt with steel cords and two parallel, integrated zero-clearance guide rail systems. A compact hard anodized aluminium profile with additionally in one-step machined internal surfaces for precise and optimal movements. The linear unit is driven by a zero-clearance drive pulley. The polyurethane timing belt is guided in the profile slot and protects all the parts in the profile from different contaminations. Lubrication ports for the central re-lubrication of the ball rail guide system.

Travel speed: $v \leq 6 \text{ m/s}$
Repeatability precision: $\pm 0,08 \text{ mm}$

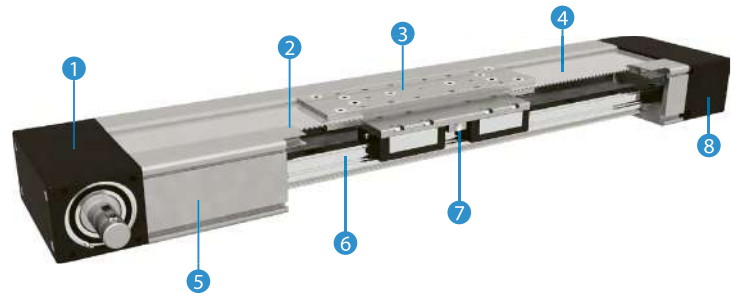

- | | |
|---|--|
| 1 - Drive block with pulley | 5 - Aluminium profile-Hard anodized |
| 2 - Aluminium cover | 6 - Two integrated Linear Ball Guideways |
| 3 - Carriage; with built in Magnets | 7 - Central lubrication port on both sides |
| 4 - AT polyurethane toothed belt with steel tension cords | 8 - Tension End with integrated belt tensioning system |



A compact linear unit with a precision-extruded aluminium profile and AT toothed belt with steel cords and zero-clearance drive pulley. The polyurethane timing belt is guided in the profile slot and protects all the parts in the profile from different contaminations. For better protection of the internal parts, the linear unit can be sealed with a corrosion-resistant protection strip. A lubrication port for the central re-lubrication of the ball rail guide system.

MTJ 40, 65, 80, 110
 Linear unit with an integrated zero-clearance guide rail system inside the profile.
Travel speed: $v \leq 6 \text{ m/s}$
Repeatability precision: $\pm 0,08 \text{ mm}$

MRJ 40, 65, 80, 110
 Linear unit with the integrated Track Rollers inside the profile.
Travel speed: $v \leq 10 \text{ m/s}$
Repeatability precision: $\pm 0,08 \text{ mm}$

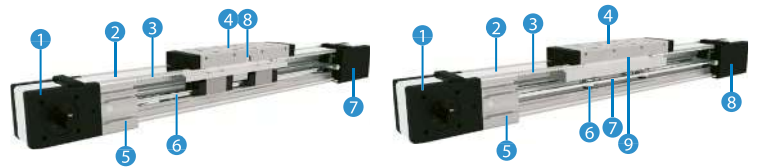

- | | |
|--|--|
| 1 - Drive block with pulley | 1 - Drive block with pulley |
| 2 - Corrosion-resistant protection strip (available also without protection strip) | 2 - Corrosion-resistant protection strip (available also without protection strip) |
| 3 - AT polyurethane toothed belt with steel tension cords | 3 - AT polyurethane toothed belt with steel tension cords |
| 4 - Carriage; with built in Magnets | 4 - Carriage; with built in Magnets |
| 5 - Aluminium profile-Hard anodized | 5 - Aluminium profile-Hard anodized |
| 6 - Linear Ball Guideway | 6 - Track Roller (journal Bearing) |
| 7 - Tension End with integrated belt tensioning system | 7 - Two hardened steel Round guide (58/60 HRC) |
| 8 - One central lubrication | 8 - Tension End with integrated belt tensioning system |
| | 9 - One central lubrication port |



The Omega linear units with an AT toothed belt with steel cords and an integrated zero-clearance guide rail system inside the profile are suitable for vertical application. The drive carriage can be stationary mounted while the aluminium profile moves in the vertical directions. This enables its low travelling mass and makes the linear unit suitable for vertical movements. A lubrication port for the central re-lubrication of the ball rail guide system.

Travel speed: $v \leq 6 \text{ m/s}$
Repeatability precision: $\pm 0,08 \text{ mm}$

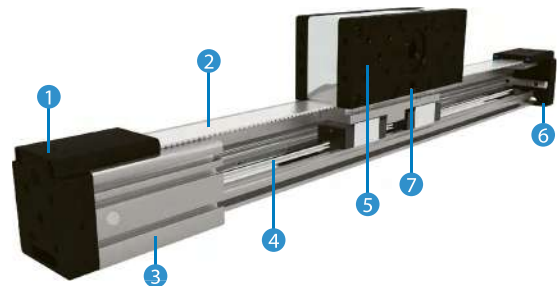

- | | |
|---|--|
| 1 - Tension End with integrated belt tensioning system | 5 - Drive block with pulley, Motor flange; with built in Magnets |
| 2 - AT polyurethane toothed belt with steel tension cords | 6 - Tension End with integrated belt tensioning system |
| 3 - Aluminium profile-Hard anodized | 7 - Central lubrication port |
| 4 - Linear Ball Guideway | |

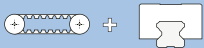

The linear unit is a powerful and cost-effective version based on precision-extruded aluminium profile and equipped with an AT toothed belt with steel cords and an integrated zero-clearance guide rail system outside the profile. It makes for easy and accurate linear movements. Lubrication ports for the re-lubrication of the ball rail guide system.

Travel speed: $v \leq 3 \text{ m/s}$
Repeatability precision: $\pm 0,1 \text{ mm}$

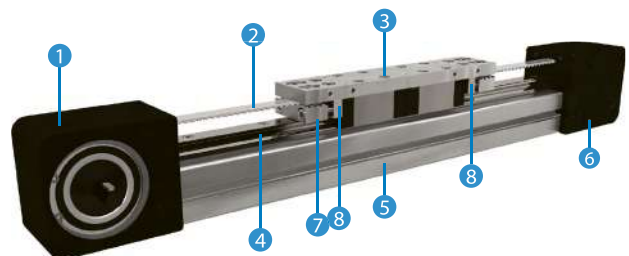

- | | |
|---|-------------------------------------|
| 1 - Drive block with pulley | 5 - Aluminium profile-Hard anodized |
| 2 - AT polyurethane toothed belt with steel tension cords | 6 - End block |
| 3 - Carriage | 7 - Belt Tension system |
| 4 - Linear Ball Guideway | 8 - Lubrication port |

BALL SCREW DRIVE



MTV SERIES - 65, 80, 110



CTV SERIES - 90, 110, 145, 200



AVAILABLE ALSO FOR
CLEANROOM APPLICATION

ACCESSORIES

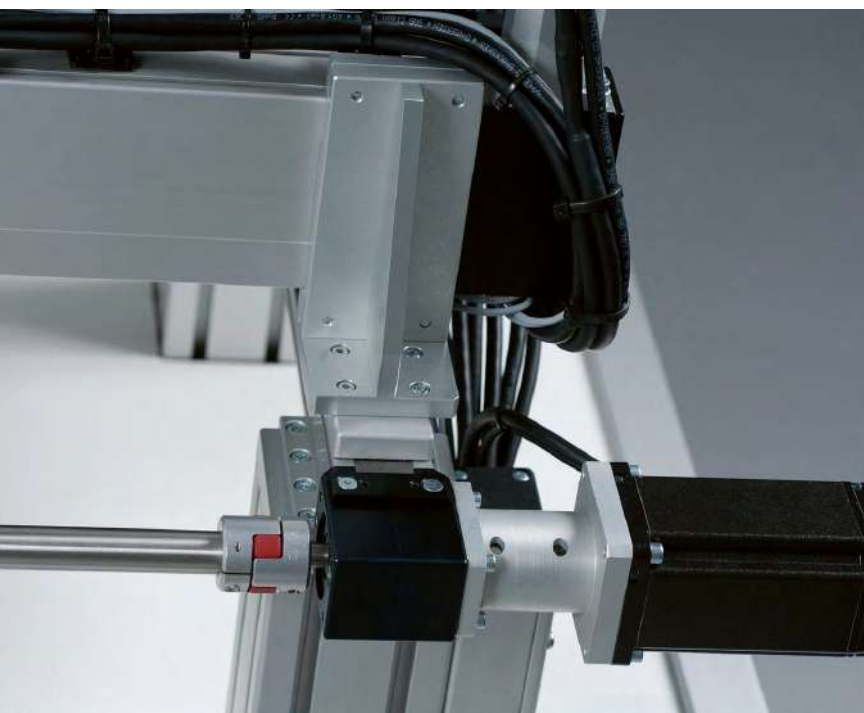

FIXING ELEMENTS

CLAMPING FIXTURES



The clamping fixtures are used for mounting the Linear units. They are placed in the slot on the side of the profile of the Linear unit.

CONNECTION ELEMENTS



Fixing and connection elements to combine the Linear units to a multi-axis system.

CENTRING RINGS



Centring rings are used to position a Linear unit on a connection plate or any customer's product on the Linear unit.



Linear units with a precision ball screw drive and integrated zero-clearance guide rail system inside the profile. A compact hard anodized aluminium profile with additionally in one-step machined internal surfaces for precise and smooth movements. The linear unit is sealed with a corrosion-resistant protection strip which protects all the parts in the profile from dust and other contaminations. A lubrication port for the central re-lubrication of the ball screw drive and the ball rail guide system.

Repeatability precision ISO7: $\pm 0,02$ mm
Repeatability precision ISO5: $\pm 0,01$ mm

Optional: Trapezoidal thread

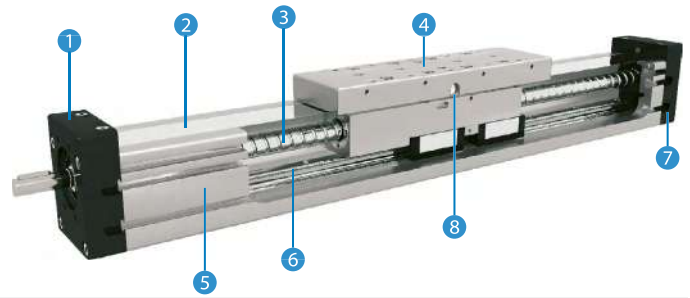

- | | |
|--|-------------------------------------|
| 1 - Drive block with floating bearing | 5 - Aluminium profile-Hard anodized |
| 2 - Corrosion-resistant protection strip | 6 - Integrated Linear Ball Guideway |
| 3 - Ball screw tolerance ISO 7
(ISO 5 available on request) | 7 - End block with fixed bearing |
| 4 - Carriage, with built in Magnets | 8 - One central lubrication port |



A compact linear unit with precision ball screw drive and two parallel, integrated zero-clearance guide rail systems. A compact hard anodized aluminium profile with additionally in one-step machined internal surfaces for precise and smooth movements. Two parallel circulating sealing strips and an aluminium cover protects all the parts in the profile from dust and other contaminations. Lubrication ports for a central re-lubrication of the ball screw drive and the ball rail guide system.

Repeatability precision ISO7: $\pm 0,02$ mm
Repeatability precision ISO5: $\pm 0,01$ mm

Optional: Trapezoidal thread

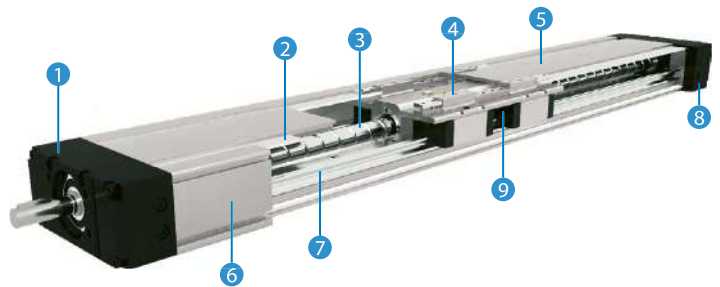

- | | |
|--|--|
| 1 - Drive block with floating bearing | 5 - Aluminium cover |
| 2 - Gap-type seal of antistatic PU strip
(recirculating) | 6 - Aluminium profile-Hard anodized |
| 3 - Ball screw tolerance ISO 7
(ISO 5 available on request) | 7 - Two integrated Linear Ball Guideways |
| 4 - Carriage; with built in Magnets | 8 - End block with fixed bearing |
| | 9 - Central lubrication port; both sides |

SENSORS



- Mechanical switch
- Induction switch
- Magnetic field sensor

MOTOR SIDE DRIVE



- Mechanical switch
- Induction switch
- Magnetic field sensor

SYNCHRONIZATION SHAFT



- For synchronizing two parallel linear units
- Backlash-free transmission and torsionally stiff
- Various executions: with an elastomer coupling or with a bellows coupling for compensation of misalignments.

MOTOR ADAPTER



- For synchronizing two parallel linear units
- Backlash-free transmission and torsionally stiff
- Various executions: with an elastomer coupling or with a bellows coupling for compensation of misalignments.



MULTI-AXIS SYSTEMS

FOR ENDLESS POSSIBILITIES.

The Linear units can be combined to various multi-axes linear systems and ensure an excellent price/performance ratio within a short delivery time. We offer a strong technical support in calculation and determination of individual multi-axis system solutions. A flexible combination of linear units with various kinds of switches, brackets, clamping fixtures and customized motor adapters provide a final multi-axis system solution available in 3D drawings.

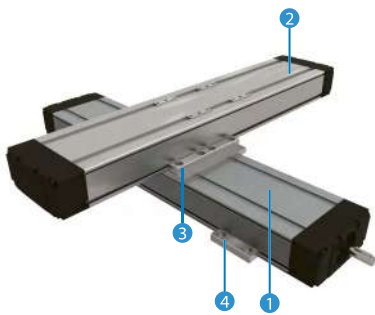

X-Y CROSS TABLE SYSTEM

- 1 - X-Axis: Ball screw driven Linear unit CTV
- 2 - Y-Axis: Ball screw driven Linear unit CTV
- 3 - Connection element with centring ring
- 4 - Clamping fixture to attach the X-Y system

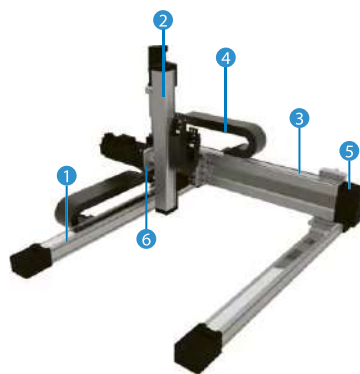

2X-Y-Z BRIDGE SYSTEM

- 1 - X-Axis: Belt driven Linear unit MTJ
- 2 - Z -Axis: Belt driven omega Linear unit MTJZ
- 3 - Y-Axis: Belt driven Linear unit CTJ
- 4 - Energy chain
- 5 - Fixing bracket with centring rings and fixing elements
- 6 - Motor adapter

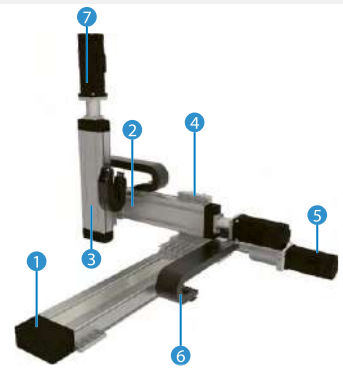

X-Y-Z SYSTEM

- 1 - X-Axis: Belt driven Linear unit CTJ
- 2 - Y-Axis: Ball screw driven Linear unit CTV
- 3 - Z-Axis: Ball screw driven Linear unit CTV
- 4 - Fixing bracket with centring rings and fixing elements
- 5 - Servo motor
- 6 - Energy chain
- 7 - Motor adapter

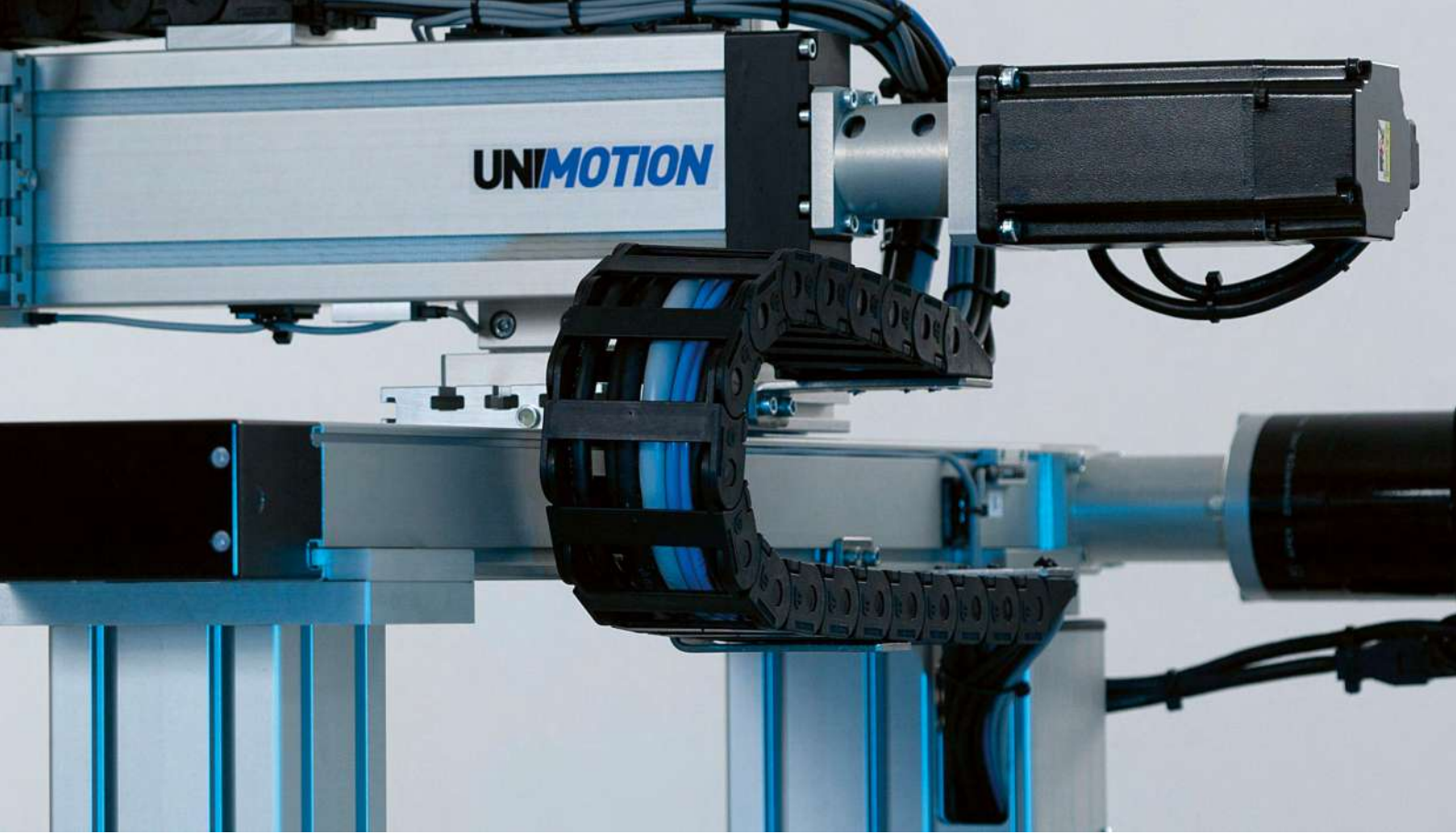

We can also build for you a gantry system or a portal as a complete assembled machine together with the frame, protections and other necessary elements to fit your exact requirements. You can use our Linear unit selection software or call our experts to save time and optimize your solution.



Selective Coating device from KC-Produkte for electronic circuit boards.

SPECIAL PROJECT AT YOUR REQUEST

Ball screw supports for higher travel speed of linear unit at long stroke.
-Maintenance-free and free-running support



XYZ Portal with Flatbed equipped.



Ball screw driven linear unit with two at the same time driven carriages. Both carriages are driven by one ball screw with left and right-hand thread.



Linear unit with two separate trapezoidal screw drive. Each carriage can be moved individually by its own drive.



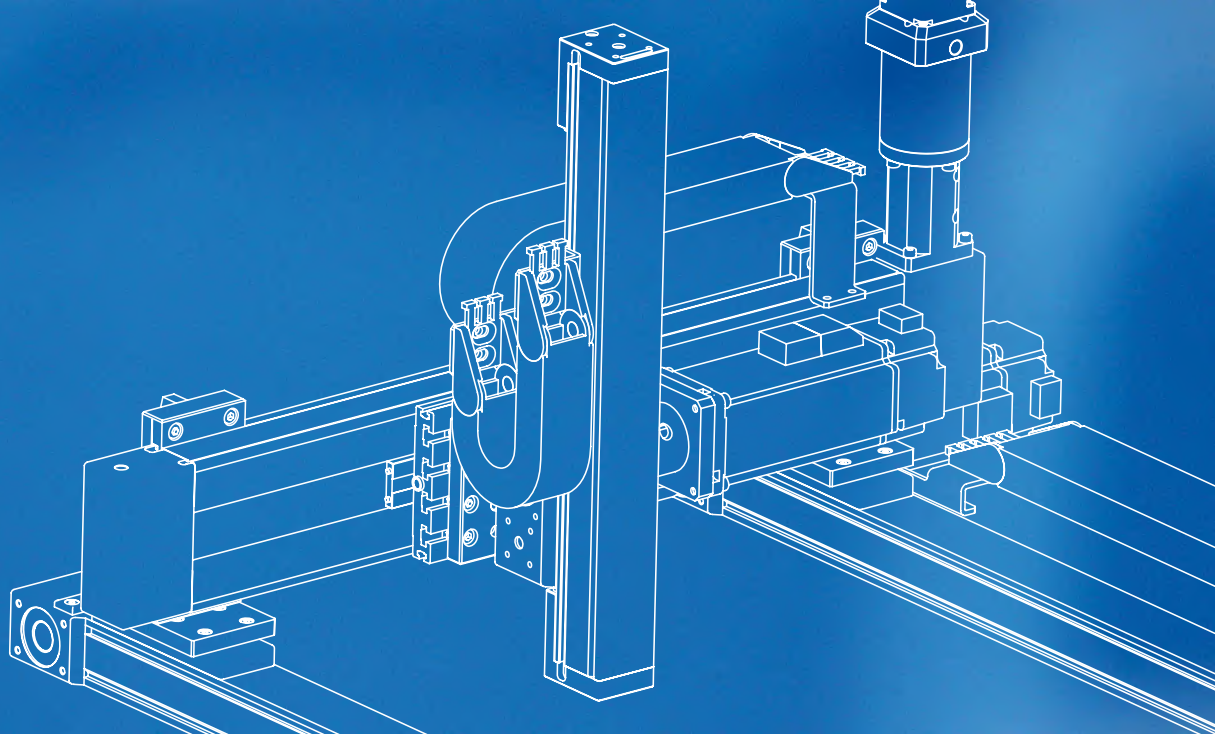

SIZING SELECTION TOOL

CALCULATE YOUR LINEAR UNIT OR ELECTRIC CYLINDER

We have many years of experience and are upgrading daily, so we can meet any challenge and can optimize the solutions for your projects. Our staff is innovative and creative, we respond quickly and are available at any point of the process, from the concept to implementation.

CALCULATE YOUR OWN PROJECT!

The calculation program "SIZING SELECTION TOOL" enables the fast and simple selection of a suitable linear axis or electric cylinder based on your application data. As a result of the interpretation of this data, the program provides you with diverse information, e.g. driving torque, rotation speed, maximal process speed, durability and other information about a particular product.



 For more information and contact forms visit us online:

www.unimotionusa.com

UNIMOTION



We cover all major markets. If you wish to contact us, send us an enquiry and we would be happy to assist you.

GERMANY

Unimotion GmbH
Waldstrasse 20
D - 78736 Epfendorf

www.unimotion.de
vertrieb@unimotion.de

NORTH AMERICA

Unimotion North America, Inc.
3952 Ben Hur Ave, Unit 5
Willoughby, OH 44094

www.unimotionusa.com
info@unimotionusa.com